

Dustroid®

Ambient Dust Monitor

Dustroid is an Online Particulate Monitoring system to measure the concentration of dust particles in the ambient air. It is capable of monitoring various particulate size ranging from 1 micron to 100 microns such as Ultrafine Suspended Particulate Matter (UFPM), Suspended Particulate Matter (SPM), Respiratory Suspended Particulate Matter (RSPM) and Total Suspended Particulates (TSP). It works on Active Sampling method to count particulate matters using a highly accurate laser beam. Dustroid can be used for dust surveys in areas with dust-laden activities like construction, mining, quarrying, ports, metallurgical processes, and many more. The data gathered from Dustroid can assist in dust suppression automation, for instance, to activate suppressants at the location once the threshold is breached.

Product Variants

Variant Name	Application	Parameter
Dustroid Smart	Urban Monitoring & Research Purposes	PM ₁ , PM _{2.5} , PM ₁₀ , PM ₁₀₀ (TSP), Temperature, Humidity
Dustroid Pro (with heated inlet)	Mining, Construction, Industrial Monitoring	PM ₁ , PM _{2.5} , PM ₁₀ , PM ₁₀₀ (TSP), Temperature, Humidity
External Modules	Optional	Wind speed & direction, Rainfall, Noise (integrable with all the 2 variants)



Sea Ports

Dust pollution at ports from harbour activities like ship movement, loading-unloading of goods can be reduced by taking timely actions by authorities.



Construction Sites

Dustroid systems can be installed at construction sites to alert authorities when dust pollution breaches the threshold limit. The solution keeps the dust emission within permissible limits.



Quarries











Dustroid can measure the dust generation due to quarrying activities and automate water cannons for dust suppression. The solution can help identify the occurrence of acute dust events.



Mines

Dustroid installation is crucial at mining sites to monitor the particulate generation and notify the dust suppression crew. The solution provides a safer working environment for the miners.

Product Features

- 
Heated Inlet: Dehumidifies the sample to nullify the effect of humidity for better accuracy. (only available in Pro variant)
- 
Weather Resistant: IP66 Grade (certified) enclosure for endurance against harsh weather conditions
- 
Retrofit Design: Plug and play design for ease of implementation
- 
On-device Calibration: On-site device calibration capability using on-device calibration software
- 
Compact: Light-weight and compact system that can be installed at 12-15 feet (4-5 m) height
- 
Over-The-Air Update: Automatically upgradeable from a central server without any onsite visit
- 
Ultimate Durability: Made of high-grade engineering-metal and composite polymers for long-lifecycle
- 
Real-Time Data: Continuous real-time-data transfer possible through various connectivity options
- 
Identity & Configuration: Each equipment carries its unique identity with geo-tagging through wireless configurable sensor
- 
Network Agnostic: Supports a wide range of connectivity options like GSM / GPRS / WiFi / LoRa / NBIoT/ Ethernet / Modbus

Levels of Calibration

Factory Calibration: The sensors are bump tested at Oizom factory to check their proper functioning with respect to each parameter.

Collocation Calibration: The sensors are calibrated against a reference station before installation to test their performance in the ambient condition.

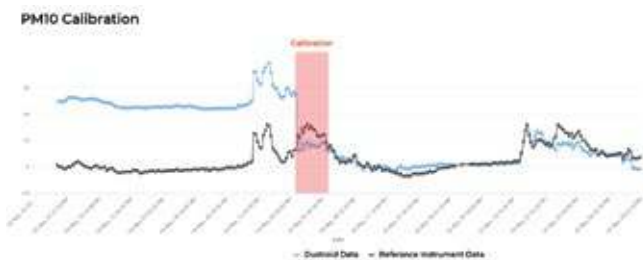

General Specifications

Size	360mm (H) x 328mm (W) x 200mm (D)
Weight	6.5 Kg (instrument weight)
Material	Aluminum Magnesium Alloy, Mild-steel (With Powder Coating), FRP
Certifications	CE & FCC Certified, PTCRB Certified Communication Module

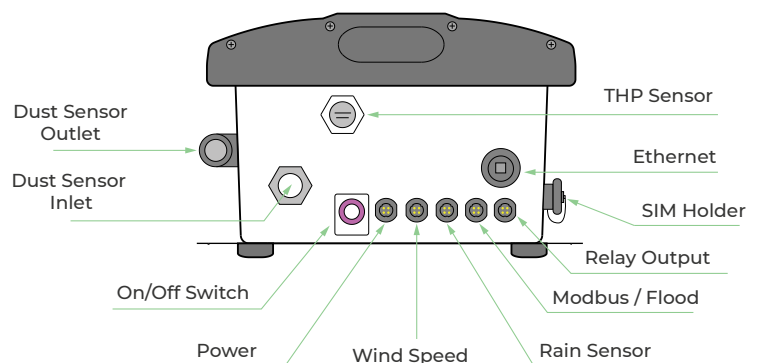

Technical Specification

Processor	Quad Core ARM Cortex
Memory	2GB RAM / 8GB eMMC ROM
Device Interface	On-device Software / API
Operating Temperature	-20 °C to 60 °C
Operating Humidity	0-95% RH

Communication

Data Interval	2-30 minutes (configurable)
Data-push Protocol	HTTP post request to host-server
Data-pull	HTTP request on device IP
Firmware Updates	Over-The-Air Firmware Update
Standby Connectivity	GSM (2G/3G) for remote diagnosis, FOTA updates, and cloud calibration

Power

Avg. Power Consumption	5 Watt (Actual consumption depends upon the number of parameters)
Power Input Options	External 110-230V AC 50-60Hz, 40Watt Monocrystal Solar Panel
SMPS Specs	24V, 2Amps output UL-62368 & CAN/CSA C22.2 Certified
Battery Backup Time	12 Hours (not available in Pro variant)
Battery Specs	Lithium iron phosphate (LiFePO ₄) battery cell with rated voltage 12.8V Capacity 6Ah

Parameters

ID	Parameter	Range	Resolution	Min. Detection	Error	Working Principle	Measurement Principle	Flow Rate	Expected Sensor Life
PM ₁	Ultra-fine Particulate Matters with size less than 1µ	0-5000 µg/m ³	0.1 µg/m ³	1 µg/m ³	Upto ± 10%	Optical Particle Counter	Continuous Flow Active Monitoring	1 L/min	1.5 years
PM _{2.5}	Suspended Particulate Matters with size less than 2.5µ								
PM ₁₀	Suspended Particulate Matters with size less than 10µ								
PM ₁₀₀	Total Suspended Particulates (TSP)	0-30000 µg/m ³							
Temp	Temperature	-40 °C to +125 °C	0.01 °C	-40 °C	N.A.	Solid State Semiconductor Sensing	Passive Monitoring	N.A.	3 years
Hum	Humidity	Up to 100% Rh	0.1 %	0.1 %	N.A.				
Bmp	Barometric Pressure	300-1100 hPa	0.18 Pa	300 hPa	±1.0 hPa / Year				

Connectivity Options		Specification
Wireless	GSM	Global 2G / 3G / 4G 868 MHz / 915 MHz CAT-M1 CAT-NB1 868 to 869 MHz, 902 to 928 MHz AP Mode and Station Mode
	LORA	
	LTE	
	NB-Iot	
	Sigfox	
Wifi		
Wired	Ethernet	Static / DHCP Configuration RS485 RTU / TCP 2 Channel
	Modbus	
	Relay Output	

Working Principle

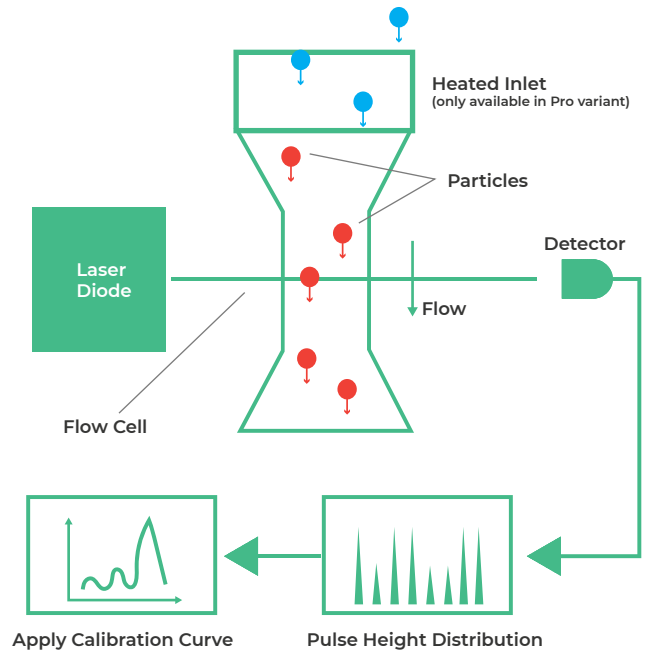

External Modules (optional)

1 **Rain Sensor**

- Tipping Bucket
- In mm / inch

2 **Wind Sensor**

- Ultrasonic sensor
- 360°, 0-40 m/s

3 **Noise Sensor**

- Capacitance
- Upto 140 dB

ID	Parameter	Range	Resolution	Min. Detection	Working Principle	Expected Sensor Life
Ws	Wind Speed	0-40 m/s	0.1 m/s	0.1 m/s	Ultrasonic	3 years
Wd	Wind Direction	0-359°	1°	1°		
Rm	Rainfall Monitoring	N.A.	0.5 mm	0.5 mm	Tipping Bucket	
Noise	Ambient Noise	Up to 140 dB	1 dB	30 dB	Capacitance	

Functional Specification

Strategic Location Selection:

As per EPA's Air Sensor Guidebook (EPA/600/R-14/159), local emission sources, buildings and other such structures can affect the Particulate Matter concentration.

Hence, it is necessary to ensure free air flow for the sensor by installing it at sufficient height from the ground level. Ideally, it should be at least 3 meter above, if possible. Also, any local PM emission sources should be avoided for precise measurements.

Installation:

Preferred Mounting	Pole / Wall (preferably 270° open surrounding)
Installation Height	12-15 feet (4-5 meters)
Direction	As per maximum direct sunlight exposure (if ambient-light monitoring is a preference)
Power Availability	Constant AC supply within a 2-meter range from the unit or solar panel
Network Availability	Uninterrupted network connection

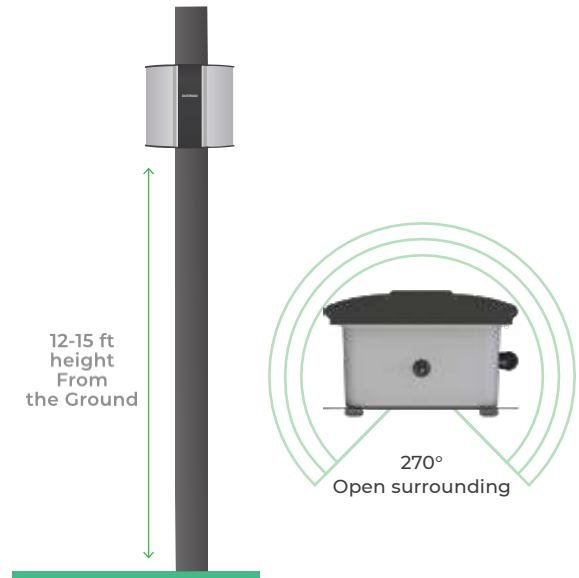

Operation:

Once the device is powered on, the device intakes air samples at a predefined frequency through the sampling system. The sensor uses light scattering method and emits a laser beam to diffract through the air sample. The intensity of the beam scattered from the particles at an angle of 45-90° informs about the particle size distribution and particle concentration.

Maintenance:



Cleaning: Periodic cleaning is important to ensure optimum device performance. Monthly or quarterly regular maintenance activity has to be carried out depending upon the surrounding. The activity includes cleaning the dome for the light sensor, air inlet, and outlet mesh & general cleaning of the exterior.



Sensor Replacement: Every sensor has a limited life span. The sensor life depends on the average pollutant concentration in the area. The sensors need to be replaced once their performance starts to deteriorate and the system starts giving unstable data.



Spot-Calibration: The frequency of calibration is decided based on atmospheric conditions and individual sensor drift to ensure data accuracy. Spot calibration can be performed using reference equipment which can also be a recently calibrated Oizom device.



Diagnosis/Debugging: Power and network availability are the prime check in case of equipment failure. If the issue is still unresolved after remote diagnosis, on-site troubleshooting can be planned by an engineer.



XEARPRO

Via delle Primule, 16
Cogliate (MB) - 20815, Italia

✉ info@xearpro.com

☎ +39 02 9646.0317

🌐 xearpro.it

Official Distributor



306, Indraprasth Corporate, Prahladnagar,
Ahmedabad - India



HB9, Savoie Technolac,
Le Bourget du Lac

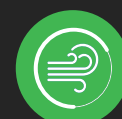

OIZOM[®]
REDEFINING RESOURCES