

CE318-T

Sun Sky Lunar Multispectral Photometer

The CE318 is the reference for automatic multispectral atmospheric photometry. Developed for the NASA in 1992, it was constantly improved to meet the growing requirements of AERONET (AErosol RObotic NETwork), the worldwide federation of networks dedicated to the measurement of atmospheric aerosols and federated by the NASA. Other independent networks like SKYNET, CARSNET, and SONENT also operate CE318 photometers.

The latest version, the CE318-T, takes advantage of cutting-edge technologies to improve metrological performance and facilitate operations. AERONET decided in 2015, after full validation, to accept only the CE318-T for new photometers entering the network.

The CE318-T performs sun, sky and lunar light measurements, for the retrieval of essential physico-optical parameters: Aerosol Optical Depth (AOD), Volume Size Distribution (VSD), complex refractive index (n), shape factor, water vapor content.

The high sensitivity tracking, detection chain and internal data processing result in enhanced measurements. Flexible communication and solar autonomy allow easy operation both on fixed sites and temporary locations.

Features

- Full autonomy with low power consumption (5 W solar panel)
- Day-time (SUN/SKY) & night-time (MOON: from 1st to last quarter) measurements:
 - AOD, VSD, n, water vapor
- Several models according to the application:
 - Standard, polarized, BRDF, BPDF, SeaPRISM (Ocean & Lake Color)
- High accuracy & long-term stability
- Flexible communication: RS232, USB, cellular modem
- AERONET compatible: fully automated & homogeneous data processing
- Secured data storage (on SD card)



Applications

- Aerosol quantification (AOD)
- Satellite calibration & data validation
- Climate research
- Atmospheric analysis
- Site validation of solar power plants
- Air quality

Technology

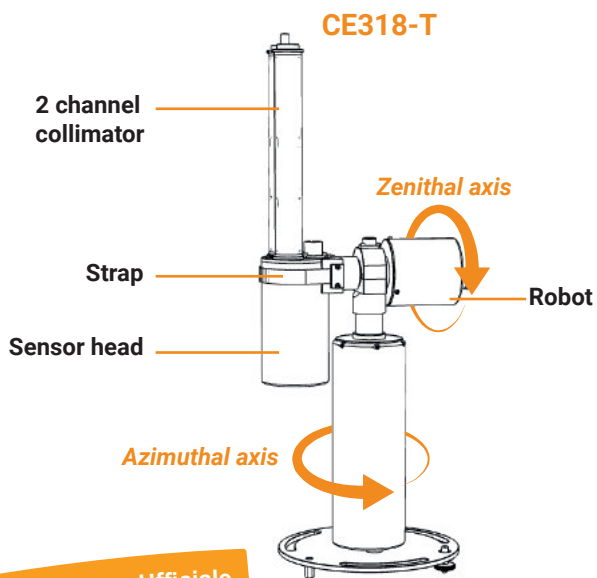

Control unit

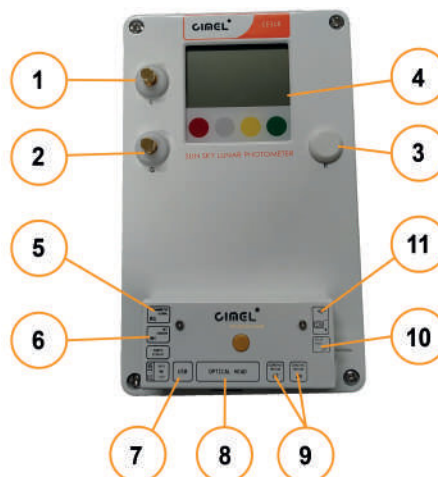

Communication & interface

- 1: GPS antenna
- 2: Cellular modem antenna
- 3: Short range radio antenna
- 4: Display (touch buttons)

Removable terminal block

- 5: Pyranometer input
- 6: Rain detector
- 7: USB
- 8: Sensor head
- 9: Robot (azimuthal & zenithal)
- 10: Solar panel
- 11: External battery

Distributore Ufficiale

Technical specifications

Sensor Head

Full scale digital count precision	< 0.1%
Half field of view	0.63°
Smallest scattering angle (from the sun) for sky measurements	2°
Spectral range	Si detector: from 340 to 1020 nm InGaAs detector: from 1020 to 1640 nm
Long term drift of single band filters' transmission rate	< 1% / year

Control Unit

Firmware	Compatible with all photometer models & all available scenarios
Data coding (measurements recording)	32 bits
User interface	- Touch keyboard - Backlight graphic display
Input & output connectors	On a single removable terminal block
Communication outputs	RS232, USB, Hexa-Band (UMTS/3G/W-CDMA), Quad-Band (GPRS)
Storage	- Flash memory (4 MB): 6 to 8 weeks data storage, for automatic transfers - SD card (32 GB): virtually unlimited capacity security for manual retrieval
Additional measurements	Rain detector, GPS, Barometer, Temperature & Humidity sensors (inside of the protection enclosure)
Additional input	Thermopile pyranometer (not supplied)
Monitoring Software PhotoGetData	Instruments setup, wavelengths selection, scan modes & scenarios configuration, measurement scheduling, data analysis, data visualization, data storage (raw data, k8, ASCII files)

Robot

Azimuth range	0° - 360°
Zenith range	0° - 180°
Resolution / tracking precision	0.003°
Sun / Moon tracking accuracy (automatic active tracking)	0.01°

Photometer models

Reference	Description	Available bands
CE318-TS9	Standard model	340, 380, 440, 500, 675, 870, 937, 1020, 1640 nm
CE318-TP9	Polarized model	340, 380, 440, 500, 675, 870, 937, 1020, 1640 nm / Polarization in three directions
CE318-TU9	BRDF measurements (9 filters)	380, 440, 550, 675, 740, 870, 937, 1020, 1640 nm
CE318-TU12	BRDF measurements (12 filters)	415, 440, 490, 555, 675, 702, 740, 782, 870, 937, 1020, 1640 nm
CE318-TV12-OC (SeaPRISM for Ocean Color)	Measurement of radiances emerging from sea water surface	400, 412.5, 442.5, 490, 510, 560, 620, 665, 779, 865, 937, 1020 nm
CE318-TV12-LC (SeaPRISM for Lake Color)	Measurement of radiances emerging from lake water surface	412.5, 442.5, 490, 510, 560, 620, 665, 681, 709, 865, 937, 1020 nm

Options

Reference	Description	Characteristics
12 m cabling	12 m cable connecting the photometer head to the acquisition unit	- Male side: Type DB15 - Female side: Jupiter type with 22 pins
15 m cabling	PC line kit for 15 m cabling length	- 15 m RS232 cord - RS232 - USB converter
100 m cabling	PC line kit for cabling length up to 100 m	- RS232 connection kit - 100 m special cable (tube cut to length) - RS232 - USB converter

Environmental conditions

Temperature range	-20°C to 50°C
Humidity range	0 to 100% RH (in non-icing condnions)

Power

Power supply	Power adapter (110 - 240 V)
Solar panel	5 W solar panel embedded in the protection enclosure of the control unit
Batteries (backup)	2 batteries 6 V / 8.0 Ah in series

Mechanical Specifications

Infrastructure	Tripod, with protection enclosure
Packaging	Flycase for transportation
Dimensions (H x W x D)	- Flycase box: 66 x 52 x 47 cm - Tripod box: 103 x 57 x 60 cm
Gross weight	- Flycase box: 30 kg - Tripod box: 21 kg

