

# Spectronus™ Trace Greenhouse Gas & Isotope Analyser

SIMULTANEOUS & REAL-TIME  
MEASUREMENTS OF CO<sub>2</sub>  
(INCLUDING δ<sup>13</sup>C & δ<sup>18</sup>O),  
CH<sub>4</sub>, N<sub>2</sub>O & CO



How do you shorten the path between monitoring and informed action?

For more than 40 years we have been designing and manufacturing class-leading multi-parameter environmental monitoring solutions. We offer our global customers a complete range of integrated measurement technologies and services, ensuring that your data is always accurate and your equipment operates with maximum efficiency.

We believe in helping you find the right balance between progress and preservation. Empowering industries, government authorities, scientists and communities to make knowledgeable decisions based on reliable data, our holistic solutions lead to operational excellence and better outcomes.

**At Acoem, we create environments of possibility.**



The background of the page features a photograph of industrial smokestacks at sunset. The sky is a mix of orange, yellow, and blue, with smoke rising from the stacks. The image is partially obscured by large, abstract shapes in blue and orange. The title 'Greenhouse gases & our future' is written in white, bold, sans-serif font in the upper left quadrant.

# Greenhouse gases & our future

As greenhouse gas emissions from human activity increase, they build up in the atmosphere and warm the climate, leading to changes in weather patterns, on land and in the oceans.

These changes affect people, society and the environment – including plants and animals.

Because many of the major greenhouse gases can remain in the atmosphere for hundreds of years after being released, their warming effect on the climate threatens to impact both present and future generations.

The ability to measure and track greenhouse gas emissions provides a global context for understanding their role in climate change and a possible roadmap for changing human behaviour to protect the planet and its resources.



## The ICOS Compliant Spectronus™

Acoem Spectronus™ (formerly known as the Ecotech Spectronus™) is the only high accuracy multispecies trace greenhouse gas and isotope analyser based on Fourier Transform Infrared (FTIR) spectroscopy. FTIR is a method that measures the absorption of infrared radiation by gases over a broad wavelength range.

Spectronus™ has been used for a variety of applications by researchers around the world for almost two decades.

As the only multispecies greenhouse and other atmospheric trace gas and isotope analyser based on FTIR spectroscopy, Spectronus™ has garnered a reputation as the only one capable of meeting World Meteorological Organisation (WMO) standard for measured species.

**The next generation Spectronus™ greenhouse gas & isotope analyser – now more user-friendly, requires less power and fits inside a standard 19-inch rack.**

**In 2019, Spectronus™ was approved by the Integrated Carbon Observation System (ICOS) as a compliant and highly precise technique for measuring greenhouse gases within its network of greenhouse gases measuring stations across Europe.**

Designed to fit comfortably in a standard 19-inch instrument rack, Spectronus™ makes high quality measurements of greenhouse gases concentrations easier. Its rack compatible size also reduces its footprint, increases mobility and decreases power consumption. The data it captures can assist industry, government and researchers in implementing targeted pollution mitigation strategies and making more informed decisions for the future.

**Next generation Spectronus™ is housed in two parts for easy mounting and easy access within a standard 19-inch instrument rack.**

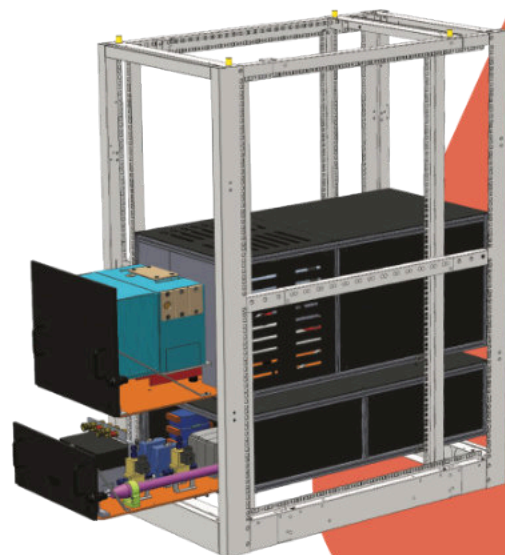

# One Instrument, Multiple Capabilities

The Spectronus™ FTIR spectrometer is a fully automated analyser that provides real-time concentration or measurements of target gases including

CARBON DIOXIDE (CO<sub>2</sub>)

CARBON MONOXIDE (CO)

METHANE (CH<sub>4</sub>)

<sup>13</sup>C/<sup>12</sup>C STABLE ISOTOPE RATIO OF CO<sub>2</sub> (δ<sup>13</sup>C-CO<sub>2</sub>)

NITROUS OXIDE (N<sub>2</sub>O)

<sup>18</sup>O/<sup>16</sup>O STABLE ISOTOPE RATIO OF CO<sub>2</sub> (δ<sup>18</sup>O-CO<sub>2</sub>)

**If the sample airstream is not dried, water vapour and its δ<sup>2</sup>H and δ<sup>18</sup>O stable isotope compositions can also be analysed.**

Spectra are analysed to determine the amounts of selected trace gases in the cell by non-linear least squares fitting of broad regions (100–200 cm<sup>-1</sup>) of the spectrum selected for each target gas. The analysis is carried out automatically after spectrum collection, and the results logged and displayed on the controlling computer.

The multi-species capability of the Spectronus™ makes it the perfect solution for any holistic greenhouse gas study. Its unique ability to measure four gases and two stable isotope ratios at once permits users to use one set of calibration gases and requires only one integrated piece of software for all measurements.

Suitably deployed, Spectronus™ can also help identify the source of a particular gas, for example the soil, or the atmosphere.

Simultaneous measurement of all gases in the same air sample allows correlations

and relationships to be identified between the greenhouse gases – something that is much more difficult using multiple analysers.

Isotopes offer the best method of understanding sinks and sources of the measured greenhouse gases. CH<sub>4</sub> and N<sub>2</sub>O measurements are valuable in any comprehensive assessment of atmospheric effects on and by climate change.

Thanks to an extended range of intuitive and user-configurable automated methods, Spectronus™ lets you investigate the mechanisms of the emission and loss of each gas, helping to resolve current uncertainties of their life cycles.

---

**“Its unique ability to measure four gases and two stable isotope ratios at once permits users to use one set of calibration gases and requires only one integrated piece of software for all measurements.”**

---



# Why Purchase a Spectronus™?

- ICOS network approved as an ICOS compliant greenhouse gas analyser
- Instrument of choice of environmental Researchers & climate scientists around the world
- Single instrument to measure the major greenhouse gases
  - Carbon dioxide (CO<sub>2</sub>) (including  $\delta^{13}\text{C}$  and  $\delta^{18}\text{O}$ )
  - Methane (CH<sub>4</sub>)
  - Nitrous oxide (N<sub>2</sub>O)
  - Carbon monoxide (CO).
- Precise & accurate measurements meet GAW requirements for trace gases
- 19-inch rackmount compatible
- Can be configured into a small wheeled rack for transportability
- Low maintenance requirements
- Spectra saved for re-analysis as required
- Exclusive "A+ Protection" program for every new Spectronus™
  - 2 year warranty
  - 5 years technical service support included.

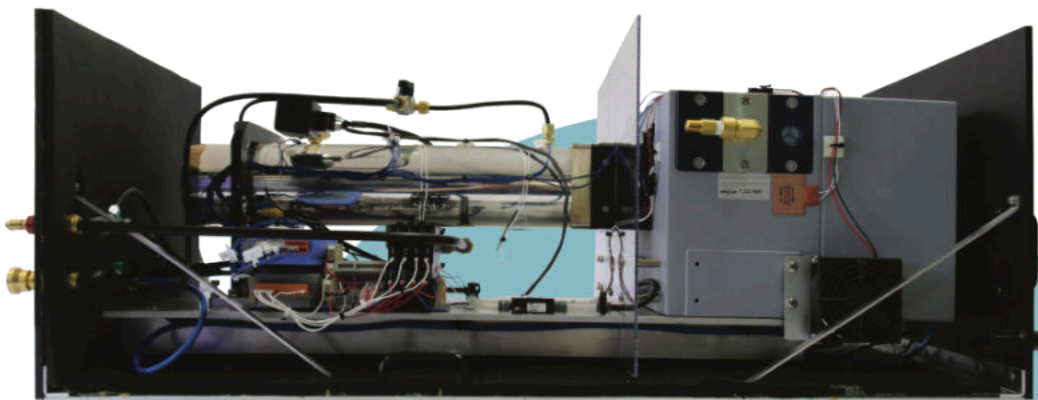

We purchased our Spectronus™ and installed the system at the U.S. Department of Energy (DOE) Atmospheric Radiation Measurement (ARM) facility located in the U.S. Southern Great Plain (SGP). Since then, the system has been performing well, and meeting our expectations. The deployment of a precise instrument for continuous measurement of CO<sub>2</sub>, CH<sub>4</sub>, CO, N<sub>2</sub>O mixing ratios, and  $\delta^{13}\text{C}$ -CO<sub>2</sub> isotopic ratios at the SGP 60 m tower, is opening up many new exciting research opportunities.

**S. Biraud, Lawrence Berkeley National  
Laboratory, USA.**

# Sensitivities

The excellent fit of the spectra allows Spectronus™ to provide a precise measurement of gas concentrations. Typical residual of the non-linear fitting is shown in Figure 1. In addition, Spectronus™ is very sensitive as shown for N<sub>2</sub>O in the Allan Deviation plot in Figure 2.

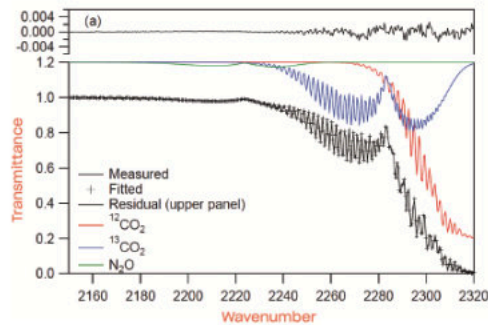

Figure 1. Measured and fitted ambient spectra (lower panel) and residuals associated (upper panel).<sup>1</sup>

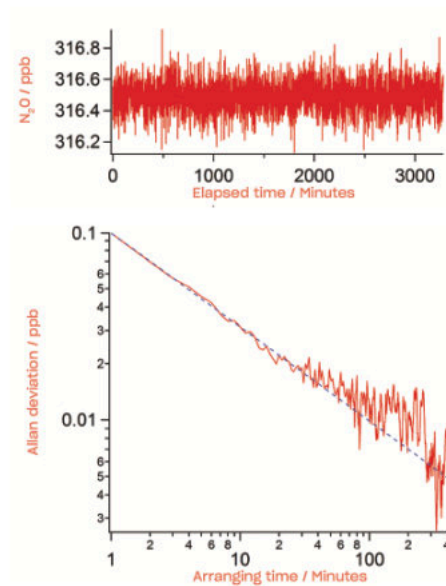

Figure 2. Spectronus™ sensitivity to N<sub>2</sub>O.<sup>1</sup>

# Stability

The stability of Spectronus™ provides the precision to meet GAW standards for trace gases with monthly or less frequent calibration. This stability is demonstrated by sampling target gas daily over 10 months – results are shown in Figure 3.

Target gas measurements can also be fully automated through one of the four standard inlets or an optional Vici-Valco multiport valve or auxiliary manifold instead of the sampling line.

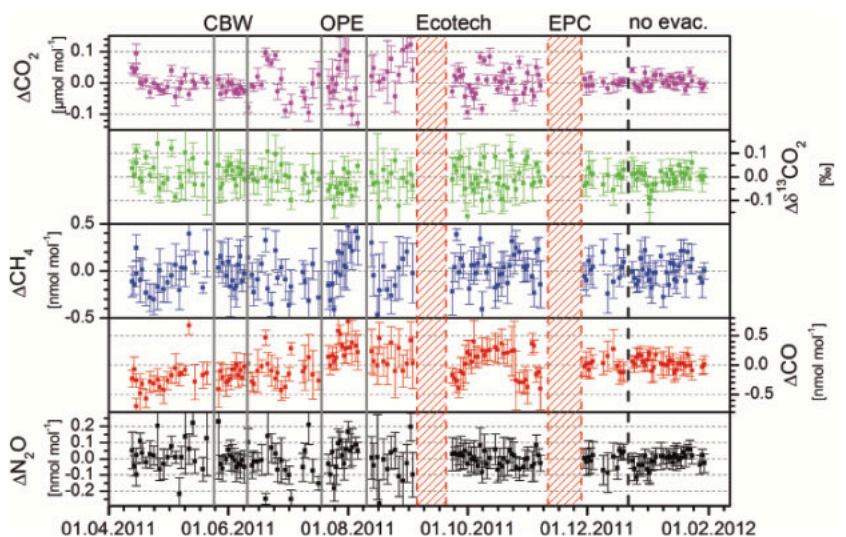

Figure 3. Ten months of measurements of a single tank.<sup>2</sup>

<sup>1</sup> Griffith, D. W. T., Deutscher, N. M., Caldwell, C., Kettlewell, G., Riggenbach, M., and Hammer, S.: A Fourier transform infrared trace gas and isotope analyser for atmospheric applications, *Atmos. Meas. Tech.*, 5, 2481–2498, <https://doi.org/10.5194/amt-5-2481-2012>, 2012.

<sup>2</sup> Hammer, S., Griffith, D. W. T., Konrad, G., Vardag, S., Caldwell, C., and Levin, I.: Assessment of a multi-species in situ FTIR for precise atmospheric greenhouse gas observations, *Atmos. Meas. Tech.*, 6, 1153–1170, <https://doi.org/10.5194/amt-6-1153-2013>, 2013.



# Applications

On a tall tower platform in the heart of the Amazon rainforest, on board a research ship or in your lab, the flexible design and configuration of Spectronus™ ensures that it

## Offshore Measurement of CO<sub>2</sub> Plumes

Spectronus™ stability, precision and robustness makes it the ideal instrument for measuring CO<sub>2</sub> concentrations in remote locations, including tracking down plumes from ships, industries or bushfires.

Spectronus™ has been employed in a number of pioneering maritime and shipbased environmental studies, including...

- Providing data on CO<sub>2</sub> and other trace gas plumes from different sources during a 2014 circumnavigation of Australia aboard the SS Southern Surveyor (see Figure 4)
- An aerosol study of the Daintree River region of Queensland in 2016
- A campaign by the Royal Australian Navy to study aerosol formation around Garden Island in Western Australia to assist with visibility for submarines.

can be easily mounted onto a standard 19-inch equipment rack in a laboratory or put on wheels to transport for deployment on site.

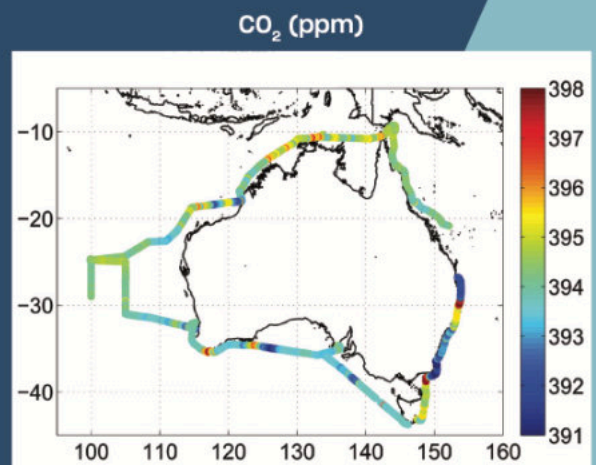

Figure 4. Ship measurements of CO<sub>2</sub> plumes. Image supplied courtesy of University of Wollongong.



In 2018, Spectronus™ was part of a University of Melbourne and University of Wollongong research study that focused on aerosol formation and the mechanism of how they formed in clean atmospheres in the Antarctica Region. A Spectronus™ was installed aboard Australia's Antarctic flagship, the Aurora Australis over four summer voyages, measuring small variations of CO<sub>2</sub> during latitudinal changes as the ship sailed, plus small amounts of carbon monoxide. See Figure 5.

Figure 5. Spectronus™ onboard – The Aurora Australis in Hobart prior its departure to Antarctica, carrying out research into atmospheric aerosols and greenhouse gases.

## Tall Tower Measurements

Tall tower measurements broaden our knowledge on regional atmospheric background concentrations by measuring above the surface layer. Vertical profiles of trace gases and isotopic fractionation can also help understand the exchange of

trace gases between the biosphere and the atmosphere. Using an Acoem manifold that staggers the measurements, differences in gas concentrations can be obtained between air parcels at different heights.

### Amazon Rainforest

While being used as part of a two-year research study on methane and other gases in the Amazon region – measuring both concentration and flux of multiple pollutants – Spectronus™ detected extraordinary and unparalleled levels of CO coinciding with the period of highly intense forest fires in Brazil.

Most of the focus for greenhouse gas studies in the Amazon has always been on CO<sub>2</sub>, with a gap in knowledge regarding Methane. Using Spectronus™ we were in a position to stop that gap and the fact that we could measure both concentration and flux of multiple pollutants, made the data we received from Spectronus™ even more valuable.

Dr Hella van Asperen, Institute of Environmental Physics, University of Bremen (Germany)

## South East Australia

Seven-point vertical profiles of each species from 2-70m were measured every 30 min, colours represent measurements at heights above the surface shown in the legend. The top of the forest canopy is approx. 40m above the surface.

Figure 6. Time series of (a) CO<sub>2</sub> and δ<sup>13</sup>C in CO<sub>2</sub> and (b) CH<sub>4</sub> and N<sub>2</sub>O during a 3-week campaign at the O<sub>2</sub>Flux tower site near Tumbarumba, SE Australia, November 2006.<sup>3</sup>

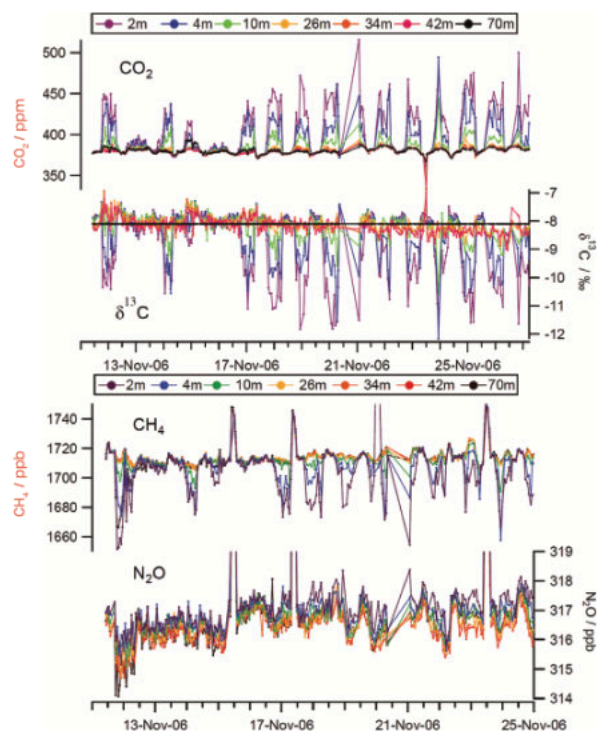



## Soil Flux Chamber Measurements

While it is important to measure land surface emissions, they are inhomogeneous and multiple measurements need to be performed to reach statistical confidence. The fully automated and remotely accessible Spectronus™ combined with a chamber system optimises the number of samples collected. It also ensures a repeatable sampling protocol, which is crucial in these measurements.

- Integrate Spectronus™ seamlessly with soil chambers for precise and reliable flux measurements.
- Control valve manifolds and chambers remotely with Spectronus™ to setup sequences as well as regulate the opening and closing of the lids.



Figure 7. Chamber measurements of soil carbon & isotope fluxes, Wombat State Forest, Australia<sup>4</sup> (Courtesy of Professor Stefan Arndt & Stephen Livesley, University of Melbourne).

<sup>3</sup> Griffith, D. W. T., Deutscher, N. M., Caldow, C. G. R., Kettiewell, G., Riggenschach, M., and Hammer, S.: A Fourier transform infrared trace gas analyser for atmospheric applications, *Atmos. Meas. Tech.*, 5, 2481–2498, 10.5194/amtd-5-3717-2012, 2012.

<sup>4</sup> Phillips, R., et al.: Tracking short-term effects of 15N addition on N<sub>2</sub>O fluxes using FTIR spectroscopy, *J. Environ. Qual.*, 42, 1327–1340, 2013.

<sup>5</sup> Fest, B. J., et al.: Soil methane oxidation in both dry and wet temperate eucalypt forests shows a near-identical relationship with soil air-filled porosity, *Biogeosciences*, 14, 467–479, 10.5194/bg-14-467-2017, 2017.



## Subterranean Measurements

Spectronus™ successfully measured trace gas variations in limestone caves to provide paleoclimatic information to better understand isotopic fractionation in speleothem layers, cave atmosphere and drip waters. See Figure 8.

### CO<sub>2</sub>, δ<sup>13</sup>C & Trace Gas Variations

One of the most important uses of δ<sup>13</sup>C measurements is in determining the strength of the different biosphere sinks. Since approximately 50 % of the carbon dioxide we add to the atmosphere each year is absorbed into various sinks, it is important for future predictions to know exactly where that carbon dioxide goes.



Figure 8. Spectronus™ was involved in a preliminary study of trace gas variations in limestone caves in 2008.<sup>6</sup>

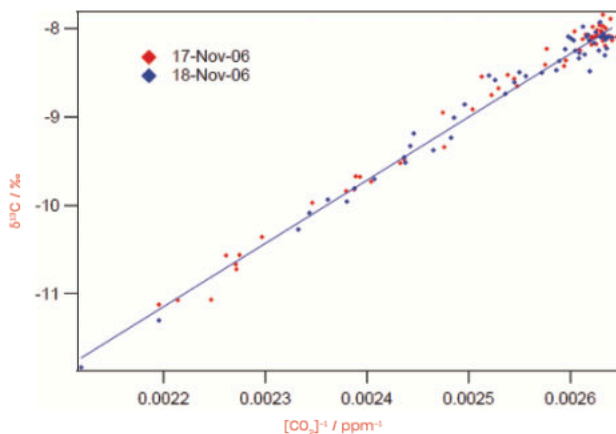

Figure 9. Isotopic ratios can help tracing sources using a Keeling plot. In this case, the intercept of the Keeling plot of δ<sup>13</sup>C vs 1/[CO<sub>2</sub>] is -26.83 ‰, indicative of respiration from the dominant C3 plants in the forest.

## Micrometeorological flux measurements

Flux measurements can be performed in many different ways. Spectronus™ is totally suitable for Relaxed or Disjunct Eddy Accumulation (REA/DEA) as well as tower gradient and profile measurements.

- Couple Spectronus™ to a sonic anemometer and our lung system to measure N<sub>2</sub>O, CO<sub>2</sub> and CH<sub>4</sub> fluxes (see Figure 10).
- The fully automated manifold will fill up, analyse and empty the bags for you.



Figure 10. Sonic anemometer for REA measurements.

<sup>6</sup> (Courtesy of Stephen Parkes, University of Wollongong, "The application of FTIR spectroscopy measuring stable isotopes of liquid water and water vapour: application to understanding speleothem growth").

# Accurate & Actionable data... always

Research campaigns, whether in the field or in the laboratory need to continuously collect data. Acoem has designed multithreaded software for Spectronus™ that ensures that your measurement data is reliable and precise throughout your project. With tasks running in parallel to analysis time, your data collection can continue whilst analysis is performed.

The software was developed for Windows 10 and designed to be user friendly. Both current and legacy data is presented intuitively via rolling graphs which can zoom in and out.

The simple user interface features standard pre-set tasks, or you can customise the tasks with no restriction on their length or complexity. Setting up the tasks is easy with the 'drag and drop' task builder. Data can be extracted from the underlying SQL database to a CSV file which is compatible with any data analysis package.

Spectronus™ can control hardware on RS232 or digital interfaces so it can be used with multiple manifold types including Vici-Valco rotary valves.

## Spectronus™ customers include

Australia's Nuclear Science and Technology Organisation (ANSTO) (AUS)

Chinese Meteorological Administration (CHN)

Finnish Meteorological Institute (FIN)

Institut Pierre Simon Laplace (LSCE) (FRA)

Korean Standards Institute (KOR)

Landcare Research - Manaaki Whenua (NZL)

Lawrence Berkeley National Laboratory (USA)

Max Planck Institute (GER)

NIWA (NZ)

University of Bremen (GER)

University of Heidelberg (GER)

University of Melbourne (AUS)

University of Sydney (AUS)

University of Wollongong (AUS).

# Specifications

Species	1- $\sigma$ precision (5 min avg)	GAW required accuracy
CO <sub>2</sub> $\mu\text{mol mol}^{-1}$	<0.02	0.1 (0.05 SH)
CH <sub>4</sub> nmol mol <sup>-1</sup>	<0.15	2.0
N <sub>2</sub> O nmol mol <sup>-1</sup>	<0.1 (5 min avg) <0.05 (10 min avg)	0.1
CO nmol mol <sup>-1</sup>	<0.15	2.0
$\delta^{13}\text{C-CO}_2$ / ‰	<0.04	0.01
$\delta^{18}\text{O-CO}_2$ / ‰	0.4	0.05
$\delta\text{D}$ in water vapour / ‰	1	N/A
$\delta^{18}\text{O}$ in water vapour / ‰	0.2	N/A

## Spectronus™ Trace Gas & Isotope System

Exceeds GAW requirements for trace gases

**ICOS**  
NETWORK  
APPROVED  
— AS AN —  
ICOS COMPLIANT  
GHG ANALYSER  
★

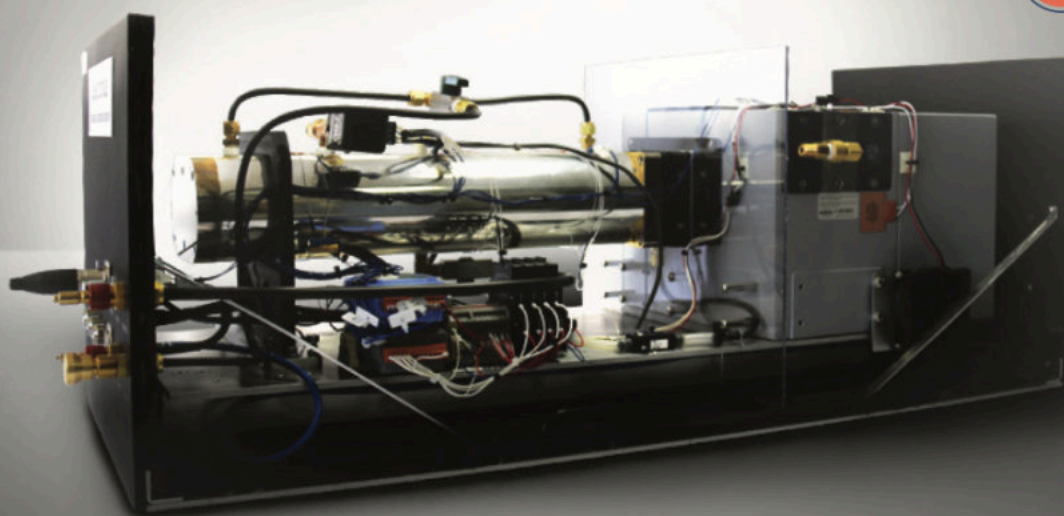

Figure 11. FTIR Spectrometer and measurement cell used in the Spectronus™.



## Precision - Allan Variance

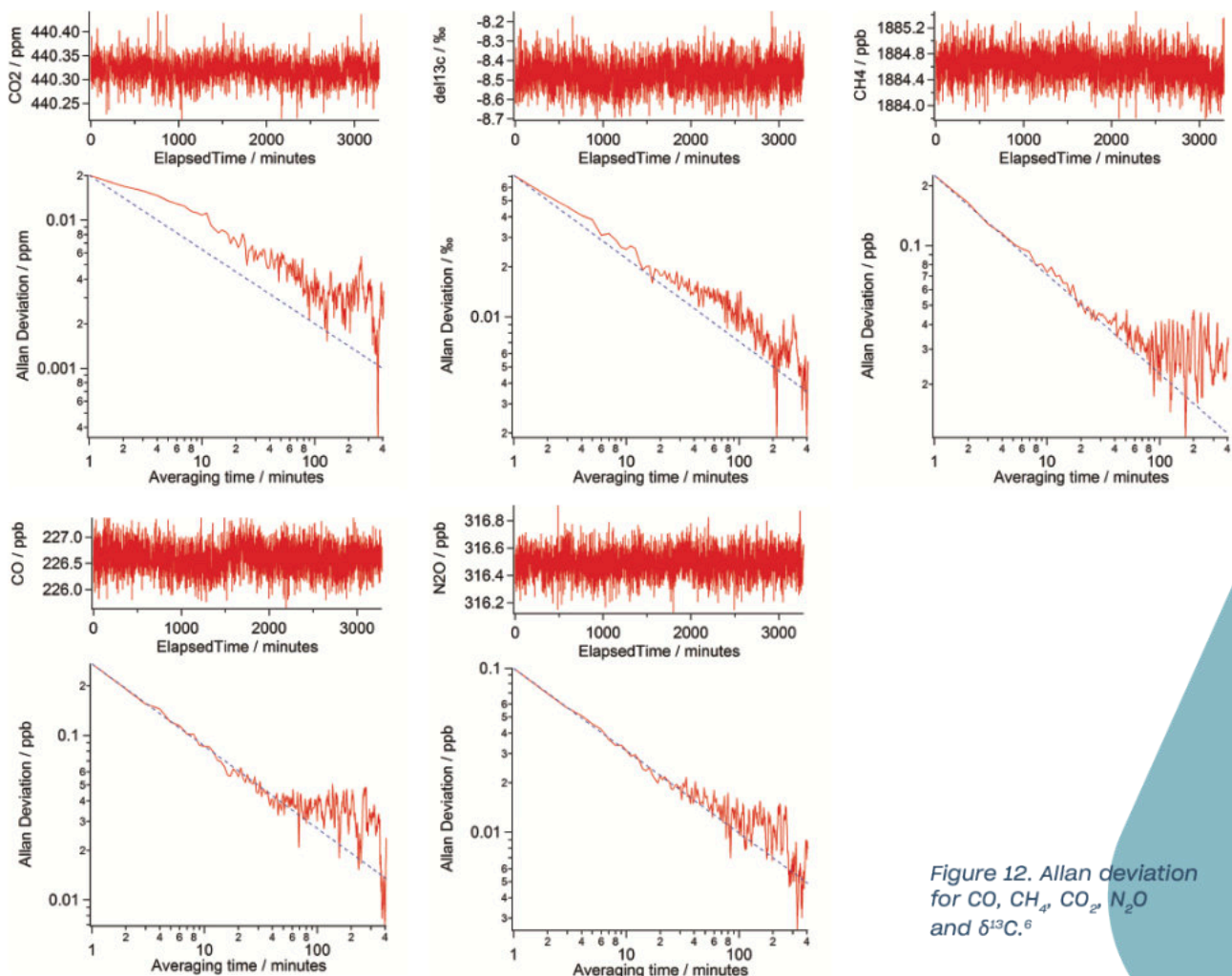

Figure 12. Allan deviation for CO, CH<sub>4</sub>, CO<sub>2</sub>, N<sub>2</sub>O and δ<sup>13</sup>C.<sup>6</sup>

**The Spectronus™ provides simultaneous measurements of multiple greenhouse gas species with high repeatability and excellent reproducibility without the need for frequent gas calibrations. The analyser consists of separate subsystems under the control of a single computer program.**

The sample handling subsystem automatically carries out all sample handling, inlet sample stream selection, cell evacuation and flushing procedures. It includes a multi-channel digital IO switching capability for switching solenoid valves, and an 8 channel analogue/digital converter for logging environmental variables such as temperatures, pressures and flows.

The FTIR spectrometer produces and records the interferogram and then performs Fourier Transformation in order to obtain the infrared spectrum of sampled air. This Spectrometer is a Bruker IR cube fitted with a thermoelectrically-

cooled MCT (Mercury Cadmium Telluride) detector (wavenumber range 1800–7800 cm<sup>-1</sup>).

The IR cube is coupled to a 26 metre multi pass gas cell that contains the air to be analysed. The spectrum analyser provides quantitative analysis of measured spectra immediately after collection, with real-time display.

Logging of analysed concentrations, analysis parameters and analogue input quantities to a SQL database and optional CSV text file is performed continuously.

<sup>6</sup> Griffith, D. W. T., Deutscher, N. M., Caldw, C., Kettlewell, G., Riggenbach, M., and Hammer, S.: A Fourier transform infrared trace gas and isotope analyser for atmospheric applications, *Atmos. Meas. Tech.*, 5, 2481–2498, <https://doi.org/10.5194/amt-5-2481-2012>, 2012.

## Spectronus™ Flow Diagram

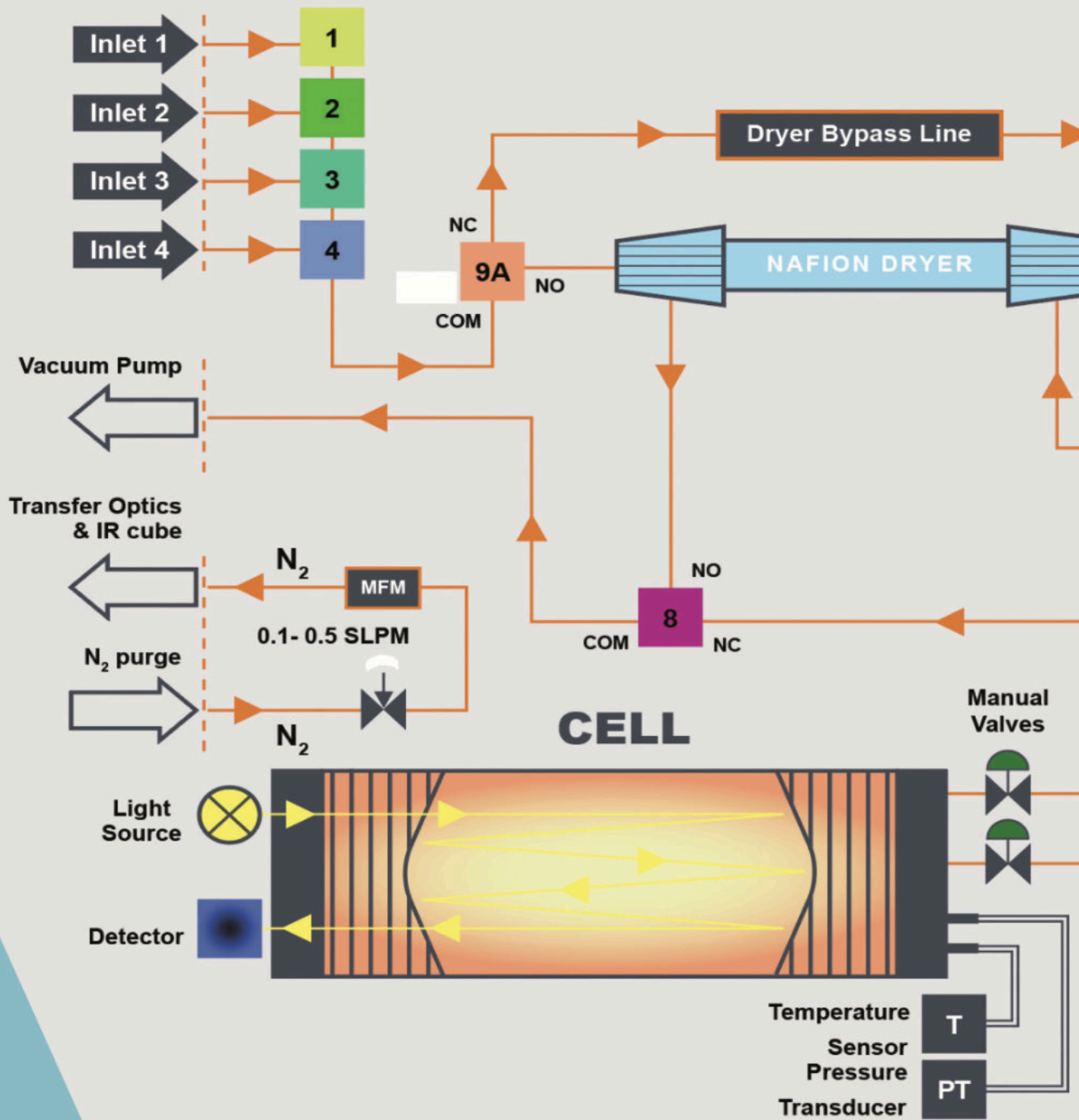

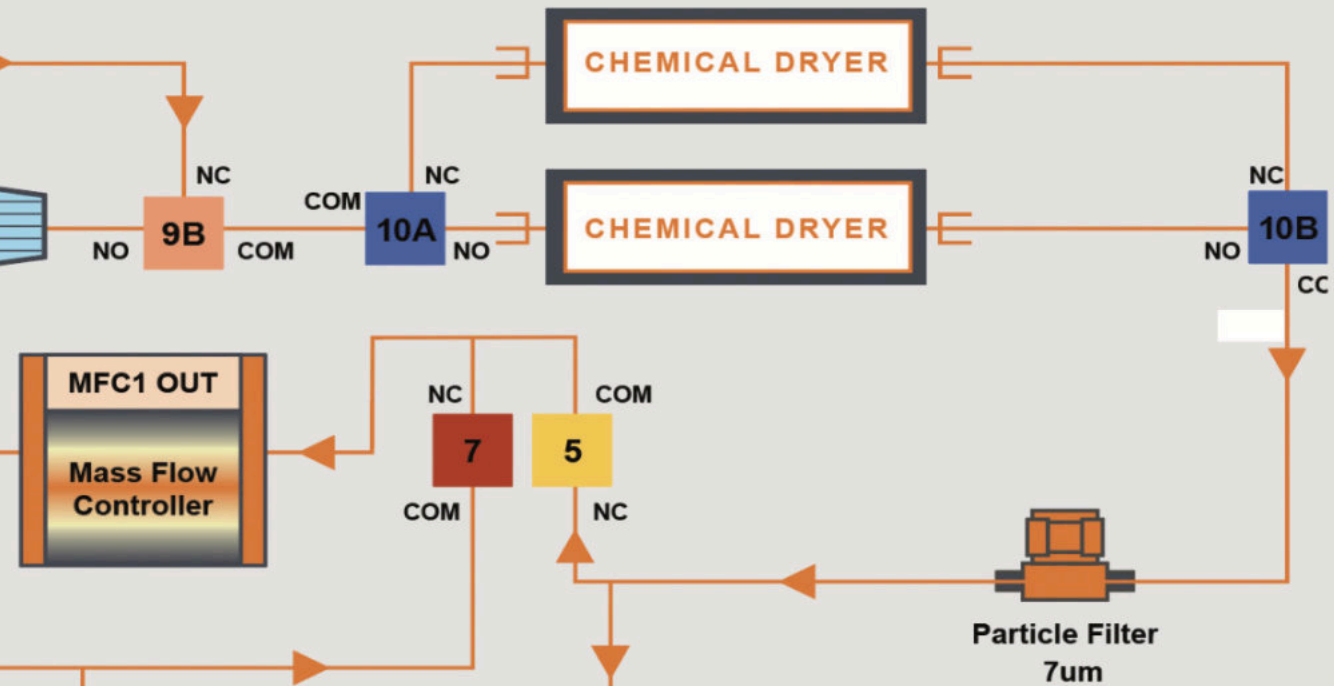

1 Inlet 1	6 Cell Inlet
2 Inlet 2	7 Cell Flow
3 Inlet 3	8 Cell Ecac
4 Inlet 4	9 Dryer Bypass
5 Bypass flow	10 Chem Dryer Select

**VALVES**



# Training & Support

Acoem offers comprehensive training packages to ensure that you receive the best possible advice and support for using our equipment. Options include extended warranty packages, onsite training and remote login to help with installation and training.

Let Acoem help you tailor a training and support package to suit your needs. Ask your Acoem representative about the "A+ Protection" program exclusive to Spectronus™ customers.







## About Acoem

**At Acoem, we create environments of possibility** – helping organisations find the right balance between progress and preservation – safeguarding businesses and assets, and maximising opportunities while conserving the planet’s resources. We deliver unrivalled, interoperable AI-powered sensors and ecosystems that empower our customers to make enlightened decisions based on accurate information.

Together with 220 distributors, our 850+ employees work across 26 offices, 6 manufacturing facilities and 5 R&D centres in 9 countries, to provide trusted, holistic data solutions for customers worldwide.

**Acoem links possibilities with protection.**

For more information visit [acoem.com](http://acoem.com)



**XEARPRO**  
Via delle Primule, 16  
Cogliate (MB) - 20815, Italia

✉ [info@xearpro.com](mailto:info@xearpro.com)  
☎ +39 02 9646.0317  
💻 [xearpro.it](http://xearpro.it)