

HIGH POWER Mie-RAMAN FLUORESCENCE LIDAR

Climate Science / Satellite / Air quality / Meteorology

THE NEED

Atmospheric aerosols have an important impact on human health in many places around the world and also on climate change through their complex interactions with solar radiation and clouds.

Numerous organizations in charge of monitoring the environment (space agencies, meteorological services, air quality agencies...) as well as the scientific community need to measure aerosols regularly at local, regional and global scales. They collect information and study their behavior in order to understand and model their impacts, detect potentially harmful events and better forecast air quality.

High-power LiDARs have become, in complement to in-situ and satellite borne instruments, an invaluable tool to analyze aerosol properties and their vertical distribution.

THE SOLUTION

Our CE710 LiDAR range is the fruit of a long term collaboration between CIMEL and the Laboratoire d'Optique Atmosphérique (LOA) within the joint laboratory AGORA-Lab.

It fulfills stringent requirements for data quality and operational robustness. In particular, it complies with the guidelines established by the pan-European Research Infrastructure ACTRIS (Aerosols, Clouds, and Trace gases Research Infrastructure).

Offering up to 15 channels, our LiDAR can profile an exceptional range of atmospheric parameters: aerosol backscatter and depolarization, aerosol fluorescence, water vapor, trace gases and temperature.

Our design facilitates customizable configurations, simple maintenance, and expandable capabilities. It is structured around the following modules:

- Telescope with tilting support
- Laser and beam expander
- Multi-channel reception and detection unit
- Electronic acquisition bay

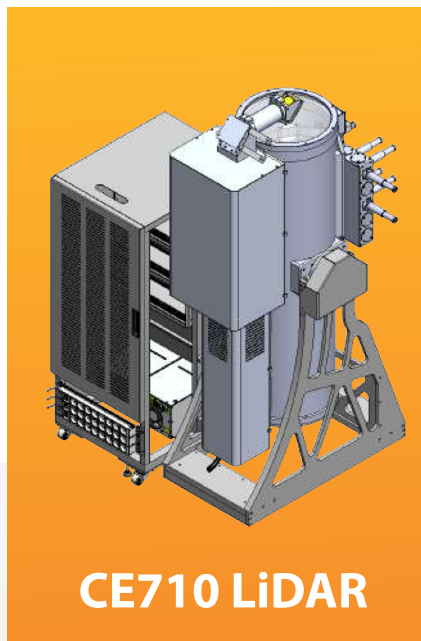

CE710 LiDAR

✉ info@xearpro.com



📍 172 Rue de Charonne,
75011, Paris - France

☎ +33 1 43 48 79 33

✉ cimel@cimel.fr

🌐 www.cimel.fr

KEY FEATURES

- ACTRIS ready
- Up to 15 detection channels (Mie-Depolarization-Raman-Fluorescence)
- Easily upgradable (additional channels)
- Integrated system, including calibration tools and remote control
- Easily transportable (compact design)
- Thermal enclosure (in option)
- Complete data processing software (AUSTRAL) integrating data from our CE318-T photometer



**Compliant with
ACTRIS guidelines
ARS-OPs-v02-rev01**

CONFIGURATION OF YOUR LIDAR

Please contact us to define together a suitable configuration to match your scientific needs and budgetary constraints.



1 LASER

Several Nd:YAG lasers are available according to your detection needs:



Laser type	Diode or pumped Nd:YAG (flash lamp / DPSSL)
Emission	Combinations of 355, 532 and 1064 nm
Operating mode	Pulsed
Repetition rate	Up to 200 Hz
Power range at 355 nm	Up to 24 W

2 TELESCOPE

We offer a large and robust telescope.

Mirror diameter	400 mm
Type	Newton
Material	Carbon fiber
Adjustable FOV	0.25-1.5 mrad

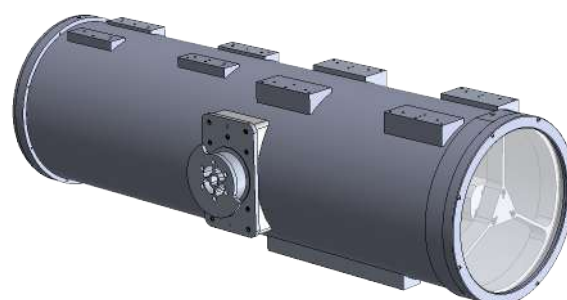

3 DETECTION CHANNELS

Our CE710 is a powerful tool to obtain profiles of aerosols, clouds, temperature, water vapor and trace gases.

Measurement channels:

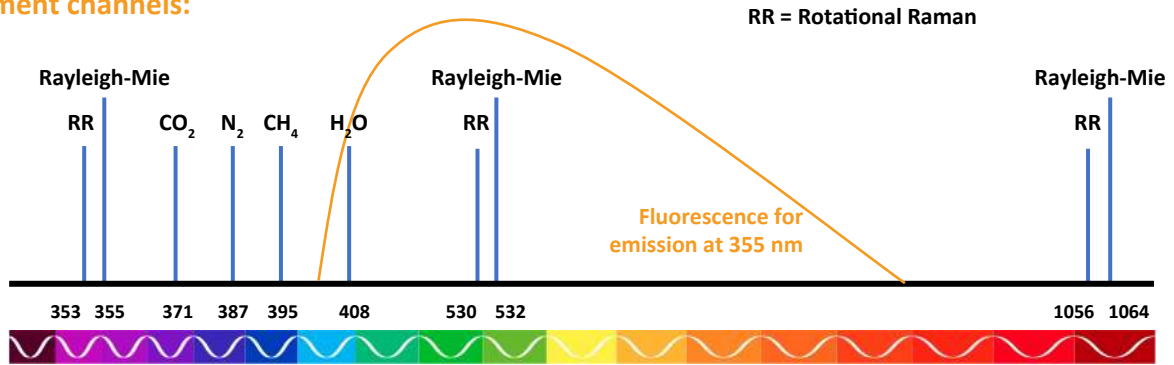

Specific Raman channels are dedicated to measurement of temperature and trace gases like CH₄ and CO₂. Profiles of aerosol parameters can be measured with Mie, Raman, depolarization and fluorescence channels.

Channel type	Wavelengths	Measured parameters
Mie backscatter	355, 532, 1064 nm	Backscatter coefficient (β)
Raman (vibrational, rotational)	387, 353, 408, 530 nm	Extinction coefficient (α)
Depolarization	355, 532, 1064 nm	Linear depolarization ratio (δ)
Fluorescence	415-520 nm	Fluorescence coefficient

The larger the number of channels, the greater the number of parameters that can be retrieved for aerosol characterization.

Configuration	Retrieved microphysical parameters
$3\beta + 2\alpha$	Volume/Surface/Number density Effective radius SSA
+ 1δ	Spherical / Non spherical
+ 1 Fluo	Classification of aerosols: Dust, pollen, smoke, urban
+ 1β WV	Water vapor mixing ratio

Depolarization channels:

Linear depolarization ratio measured at several wavelengths allows to distinguish cloud phase, to identify irregularly-shaped particles (dust, pollen, ash) and can be used for particle classification.

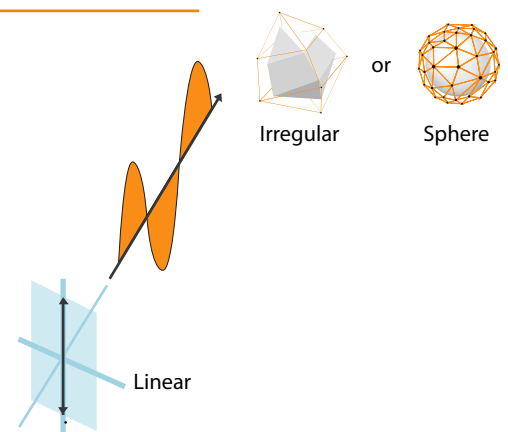

Fluorescence channels:

Fluorescence spectroscopy is a highly sensitive technique, widely used for the in-situ monitoring of atmospheric organic particles. By adding the fluorimetry into our LiDARs, we extend this information to vertical profiles. The fluorescence spectrum is sensitive to aerosol type and composition, therefore making their identification possible.

Examples of aerosols our solution can distinguish:

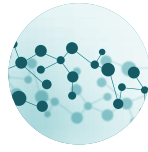

Organic aerosols



Pollen



Smoke

4 THERMAL ENCLOSURE

The CE710 LiDAR must operate in a controlled environment: $23 \pm 5^\circ\text{C}$ with $< 90\%$ relative humidity.

To perform optimally, the telescope must have a direct view on the sky (without glass).

The enclosure is equipped with a rain detector and automatic hatch.

Operational environmental conditions

External temperature	Down to -10°C Up to 55°C
Weight	$< 200\text{ kg}$

5 ADVANCED DATA ANALYSIS - AUSTRAL SOFTWARE

Our LiDAR comes with the advanced data analysis software **AUSTRAL** (AUtomated Server for the TReatment of Atmospheric Lidars) developed by LOA within AGORA-Lab.

You can visualize and interpret the data collected by the instrument in real-time through Quicklooks of Range Corrected Signals (RCS), Volume Depolarization Ratio (VDR) as well as inversion results (extinction and backscatter, fluorescence coefficient and water vapor profiles).

This allows you to quickly and easily identify patterns and trends in the data, enabling you to draw more accurate insightful conclusions about atmospheric phenomena.

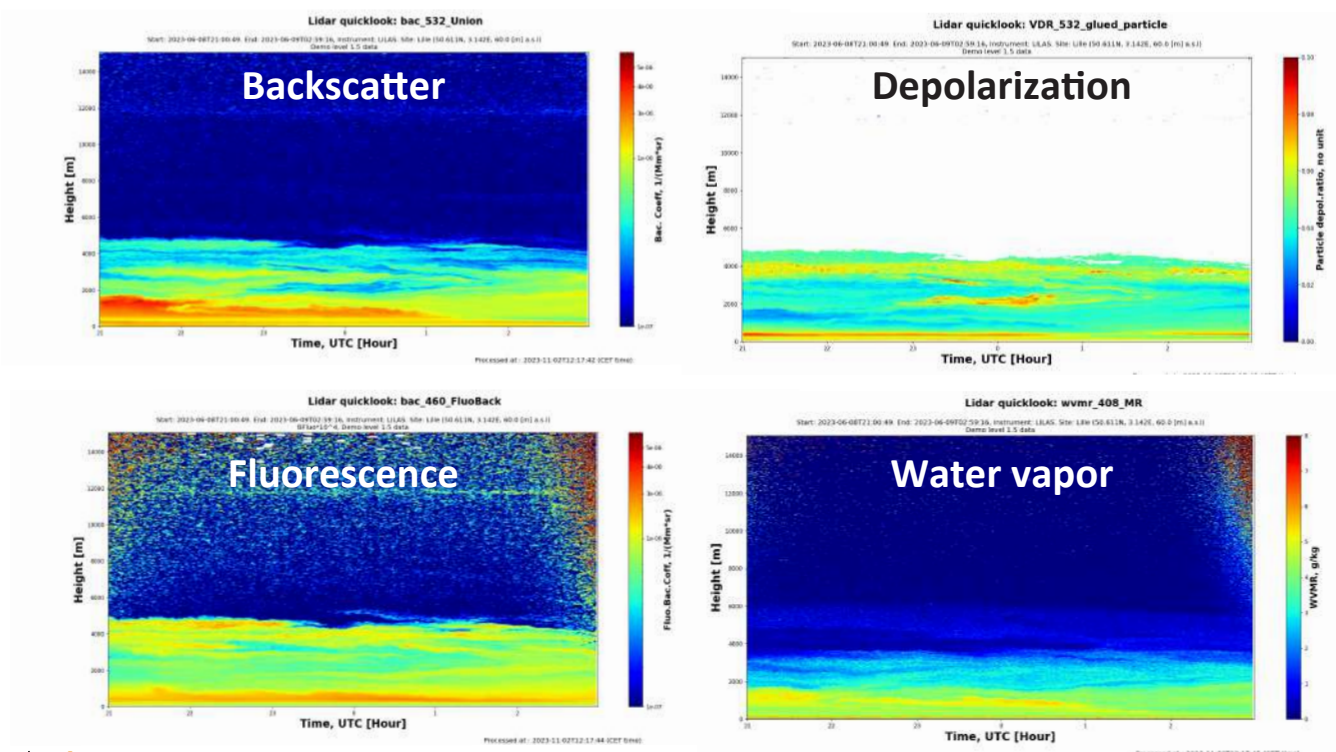

Combining technology and science, CIMEL develops remote sensing instruments for monitoring the atmosphere and oceans, which contribute to the understanding of the Earth system and the adaptation of human activities to the environment.

TECHNICAL PARAMETERS

Parameters	Examples of configurations		
	ACCESS	PRO	XPERT
Channels	1 β + 1 α + 1 δ at 355 nm <u>OR</u> 1 β + 1 α + 1 δ at 532 nm	1 β + 1 α + 1 δ at 355 nm and 1 β + 1 α + 1 δ at 532 nm	1 β + 1 α + 1 δ at 355 nm and 1 β + 1 α + 1 δ at 532 nm and 1 β + 1 δ at 1064 nm
Elastic channels	355 <u>OR</u> 532 nm	355, 532 nm	355, 532, 1064 nm
Rotational Raman channels	353 <u>OR</u> 530 nm	353, 530 nm	353, 530, 1056 nm
Laser energy at 355 nm	100 mJ / 20 Hz	120 mJ / 20 Hz	100 mJ / 100 Hz
Laser energy at 532 nm	100 mJ / 20 Hz	100 mJ / 20 Hz	100 mJ / 100 Hz
Laser energy at 1064 nm	N/A	160 mJ / 20 Hz	200 mJ / 100 Hz
Height resolution		3.75 - 15 m	
Temporal resolution		≥ 10 s	
Overlap		≤ 750 m	
Acquisition electronics		Licel (Analog, PhC)	
Operating temperature		23 \pm 5°C (w/o a thermal enclosure) -10°C to 55°C (with a thermal enclosure)	
Water vapor	○	●	●
Fluorescence	○	●	●

QA features - ACTRIS ready

Dark signal measurement	●	●	●
Alignment camera	●	●	●
Polarization calibration	●	●	●
Telecover	●	●	●
Pre-trigger	●	●	●



Scan to see the website



XEArPro Srl. - Distributore Ufficiale
 Via delle Primule, 16 - Cogliate (MB)
 Phone: +39 02 9646.0317
 Email: info@xearpro.com
 www.xearpro.it