

FC Series Humidifiers

Consistent Humidification for High-Flow Applications

Perma Pure FC Series humidifiers use an exclusive Nafion™ membrane tubing to continuously humidify gas streams. These humidifiers operate over a wide range of flow rates and can use either liquid water or a humid gas stream as a source of humidity.

Key Features

- Humidifies continuously
- Transfers only water vapor
- Self-regulating
- High level of humidification
- Maintenance-free operation
- No moving parts
- Excellent corrosion resistance
- Humidifies high flow rates

Principle of Operation

Perma Pure's FC Series gas humidifiers are tube-in-shell humidity exchangers that transfer heat and water vapor between two gas streams. They may operate as either water-to-gas or gas-to-gas humidity exchangers.

Water-to-gas humidifiers have liquid water on one side of the tube wall and a dry gas on the other. This arrangement offers the greatest amount of humidification; however, the reaction of the water molecules moving through the tubing wall absorbs heat. To counter this cooling effect, the inlet water must be heated. Hot, circulated deionized water should be used to optimize performance.

Gas-to-gas humidifiers use counter-flowing wet and dry gas streams to move heat and humidity from one stream to the other. These units are energy efficient, as they do not require any additional power or heat. When gas passes inside the Nafion™ tubing, water is absorbed by and moves through the walls of the tubing. The movement of water is driven by the humidity gradient between the inside and outside of the tubing. Since only water molecules move through the tubing walls, liquid water is prevented from becoming entrained in the gas stream.



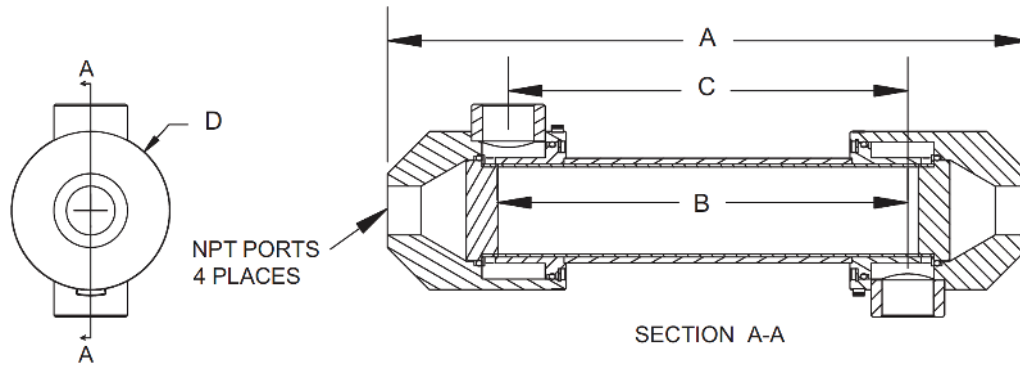

| Model | A | | B | | C | | D | Port Sizes | Operating Fluid Pressure Range | |
|------------------------|--------|-------|--------|-------|--------|-------|------|---------------------------------|--------------------------------|---------------------------|
| | inches | mm | inches | mm | inches | mm | | | inches | kPa |
| FC100-80 | 8.8 | 223 | ? | ? | 5.4 | 135 | 1.3 | 1/4 air inlet 1/8 wet stream | 0 to 35 @ 80°C (176°F) | 0 to 5 @ 80°C (176°F) |
| FC125-240-5MP | 7.9 | 200.7 | 5 | 127 | 4.6 | 116.8 | 2.5 | 1/2 | 0 to 172 @ 80°C (176°F) | 0 to 25 @ 80°C (176°F) |
| FC125-240-7MP | 9.9 | 251.5 | 7 | 177.8 | 6.6 | 167.6 | | | | |
| FC125-240-10MP | 12.9 | 327.7 | 10 | 254 | 9.6 | 243.8 | | | | |
| FC150-480-7PP | 11.5 | 292.1 | 7 | 177.8 | 6.75 | 171.5 | 3.5 | 3/4 | 0 to 172 @ 80°C (176°F) | 0 to 25 @ 80°C (176°F) |
| FC150-480-10PP | 14.5 | 368.3 | 10 | 254 | 9.75 | 247.7 | | | | |
| FC150-480-15PP | 19.5 | 495.3 | 15 | 381 | 14.75 | 374.7 | | | | |
| FC200-780-7MP | 11.1 | 281.9 | 7 | 177.8 | 6.16 | 156.5 | 3.52 | ? | ? | ? |
| FC200-780-10MP | 14.1 | 358.1 | 10 | 254 | 7.16 | 181.9 | | | | |
| FC300-1660-7LP | 12.1 | 307.3 | 7 | 177.8 | 5.6 | 142.2 | 5.2 | 1 1/2 | ? | ? |
| FC300-1660-10LP/ HP | 15.1 | 383.5 | 10 | 254 | 8.6 | 218.4 | | | | |
| FC300-1660-15LP | 20.1 | 510.5 | 15 | 381 | 13.6 | 345.4 | | | | |
| FC400-2500-7LP/HP | 12.8 | 325.1 | 7 | 177.8 | 5.0 | 127 | 6.11 | 1 (2 optional) | ? | ? |
| FC400-2500-10LP | 15.8 | 401.3 | 10 | 254 | 8.0 | 203.2 | | | | |
| FC600-7000-7PP | 14.75 | 374.7 | 7 | 177.8 | 5.75 | 146.1 | 8.5 | 2 | 0 to 35 @ 80°C (176°F) | 0 to 5 @ 80°C (176°F) |
| FC600-7000-10PP | 17.75 | 450.9 | 10 | 254 | 8.75 | 222.3 | | | | |
| FC600-7000-15PP | 22.75 | 577.9 | 15 | 381 | 13.75 | 349.3 | | | | |

XEarPro s.r.l. Distributore esclusivo italiano

S. legale: Via delle Primule, 16
Cogliate (MB), 20815, Italia

S. operativa: Via XXV Aprile, 41
Barlassina (MB), 20825, Italia

+39 02 9646.0317 info@xearpro.com

www.xearpro.it

Perma Pure LLC • A Halma Company • info@permapure.com • www.permapure.com

1001 New Hampshire Ave., Lakewood, NJ 08701 USA

Lit. No.: FC-Series-Flyer-1810 Supersedes: FC-Series-Flyer-1802

©2018 Perma Pure LLC. All rights reserved. Speculations subject to change.

Nafion™ is a registered trademark of The Chemours Company.